



SPRAYZONE.NET
SPRAY BOOTH MANUFACTURING
REFINISHING TECHNOLOGIES

AUTO PREMIUM | AUTO STANDARD | TRUCK BOOTH | OZONE | PREP-STATION | OPEN FACE

▾ | **HEATING UNIT**

CEILING MOUNT | ROOF MOUNT | OUTSIDE PAD MOUNT | CEILING SUSPENDED



HEATING UNIT

SprayZone.net offers a wide range of heating units to fit all your heated air handling needs. From outdoor to indoor, ceiling suspended to outside roof mounted, we can achieve any of your production shop requirements.



HEATING UNIT FEATURES

CONFIGURATIONS

- Indoor or outdoor installation
- Vertical, horizontal or suspended configurations
- Roof, ceiling or stand-alone mounting
- Many varieties of sizes and options

CONSTRUCTION

- Highly durable 16 gauge construction
- Double wall panels insulated 2" thick
- Pre-painted (White In & Out) Panels
- Plastic protection for easy handling
- Tongue and groove joints

ENERGY-EFFICIENCY

100% of available heat in the air stream, it is not taken from a flue.

CERTIFICATION

ETL listed



HEATING

- 1,000,000 BTU heater
- Spray temperature 55 to 90
- Bake temperature 90 to 160

FEATURES

- External access for profile dumpers
- Adjustable drives
- Pre-wired and factory tested, approved
- Pressure differential airflow option
- High-temperature limit

ACCESSORIES

- V-Bank filter section
- Motorize discharge dampers or motorized inlet
- Fresh air hood
- Service platforms
- Exhaust variable frequency drive
- UL listed control panels

MAINTENANCE

- Large panels for easy access and maintenance
- Motors and drives out of the air stream

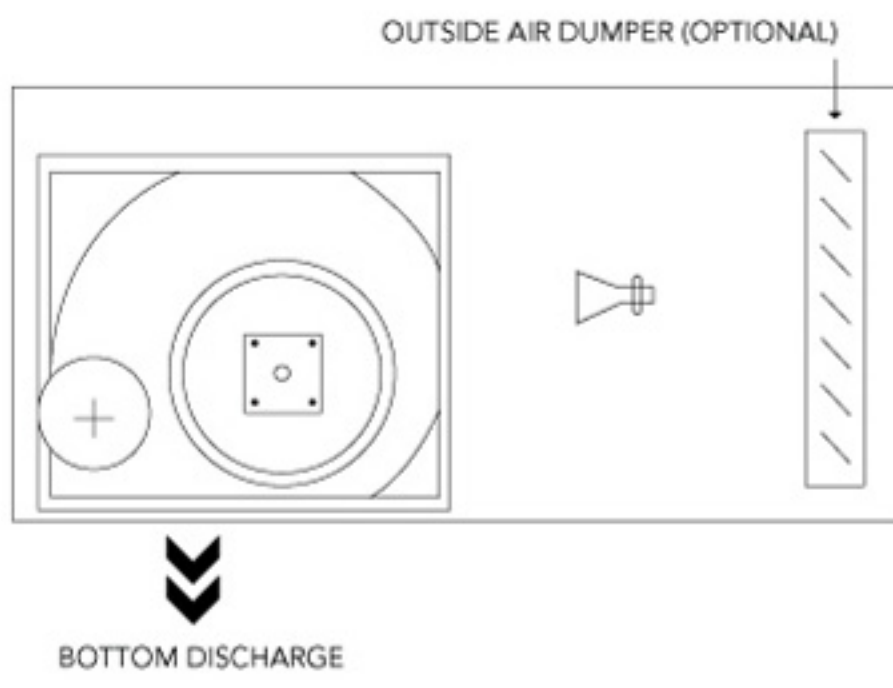

CONSTANT VOLUME

DESIGN :
100% outdoor air during paint & bake cycles.
Fixed discharge air volume.

FUNCTION :
Provides constant fresh air to the booth.

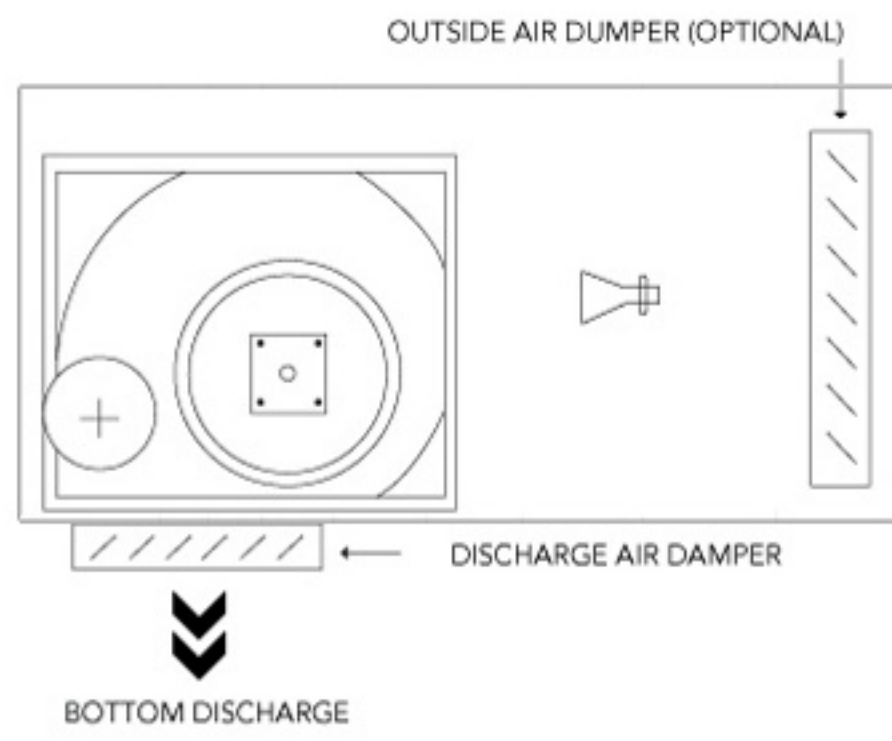

REDUCED VOLUME BAKE CYCLE

DESIGN :
100% outdoor air during paint and bake cycles.
Discharge air volume reduces to 50% during bake.

FUNCTION :
Reduced airflow in bake reduces gas consumption.

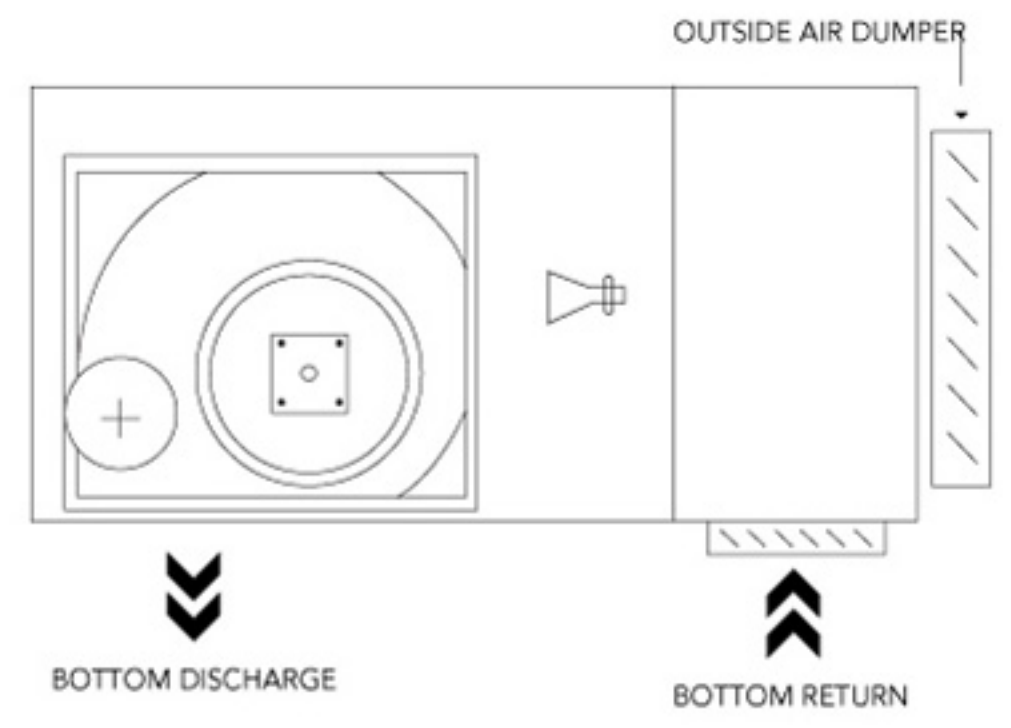

RECIRCULATED BAKE CYCLE

DESIGN :
100% outdoor air during paint and bake cycles. Fixed
90% return air / 10% outdoor air during bake.

FUNCTION :
Recirculates heated air for reduced gas consumption.

HEATING UNIT MODELS

CONSTANT VOLUME | REDUCED VOLUME | RECIRCULATED BAKE CYCLE



HEATING UNIT DISCHARGE CONFIGURATIONS

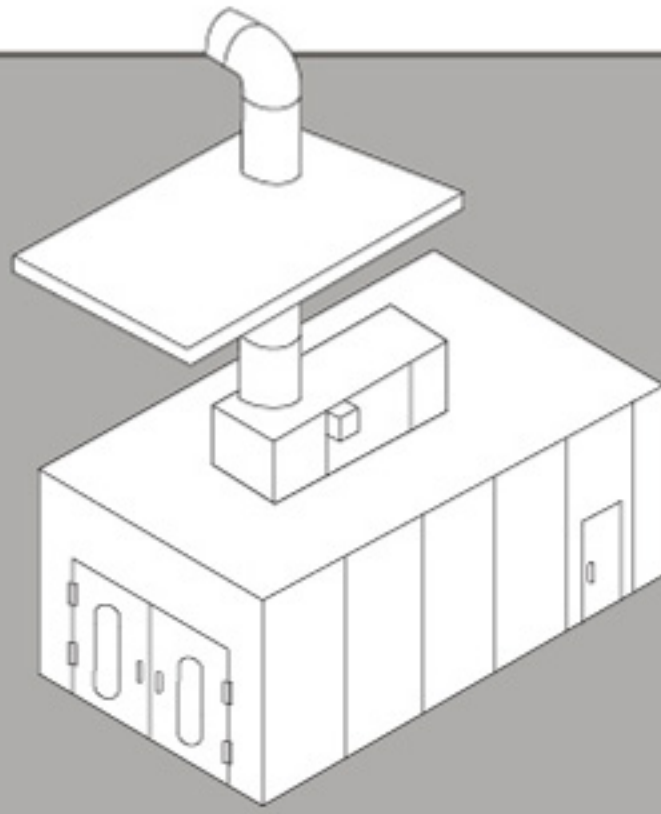

CEILING [INSIDE] MOUNTED // BOTTOM DISCHARGE

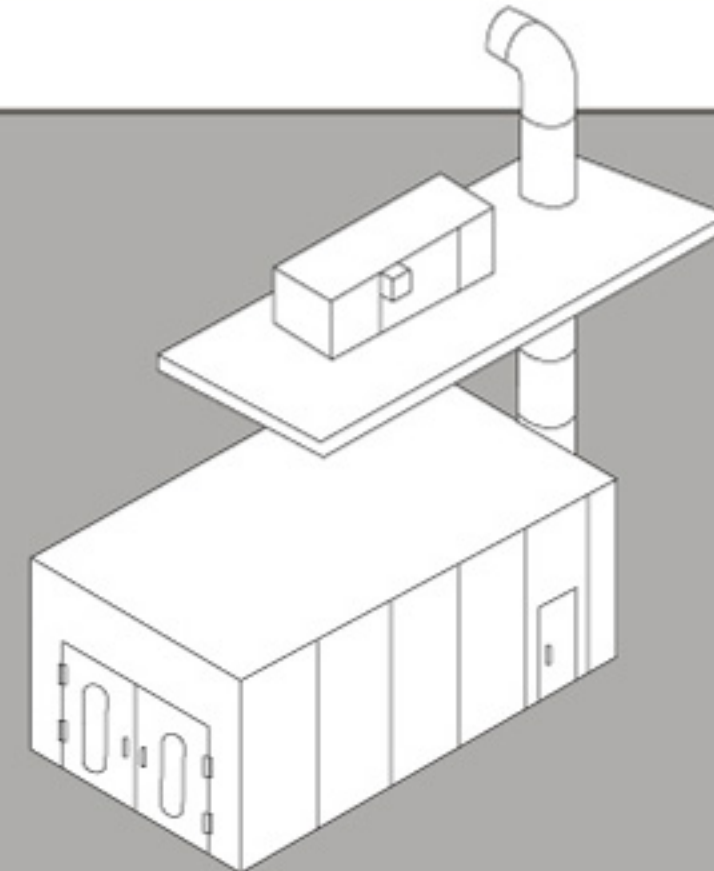

ROOF [OUTSIDE] MOUNTED // BOTTOM DISCHARGE

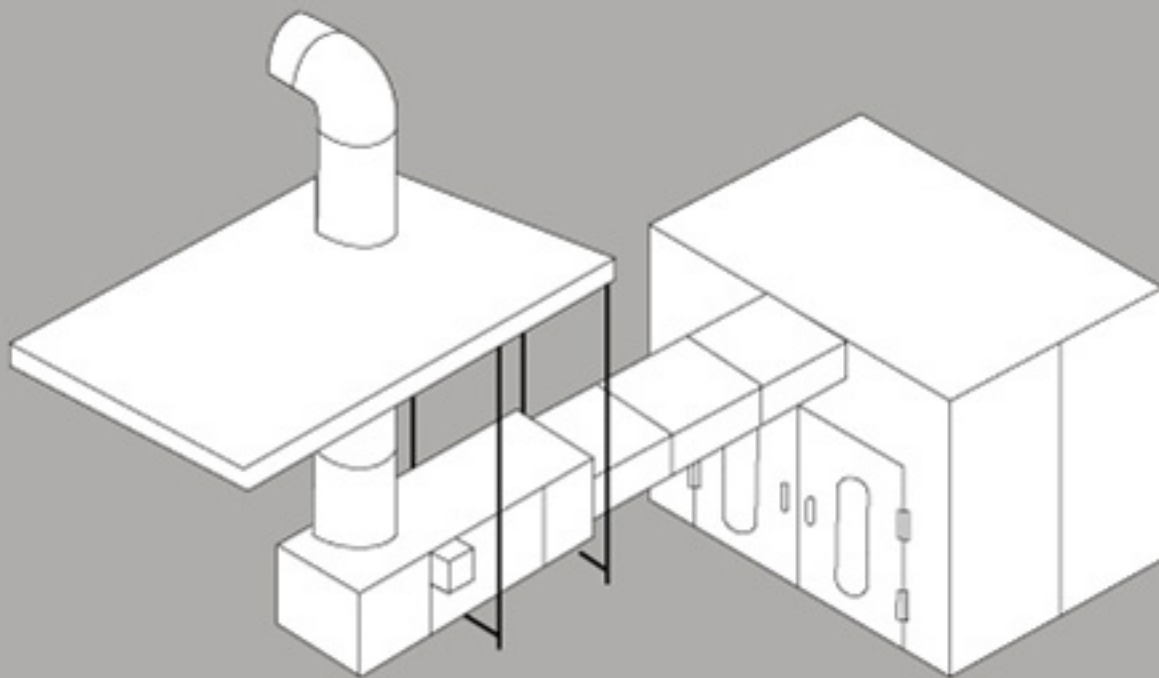

CEILING [INSIDE] SUSPENDED // END DISCHARGE

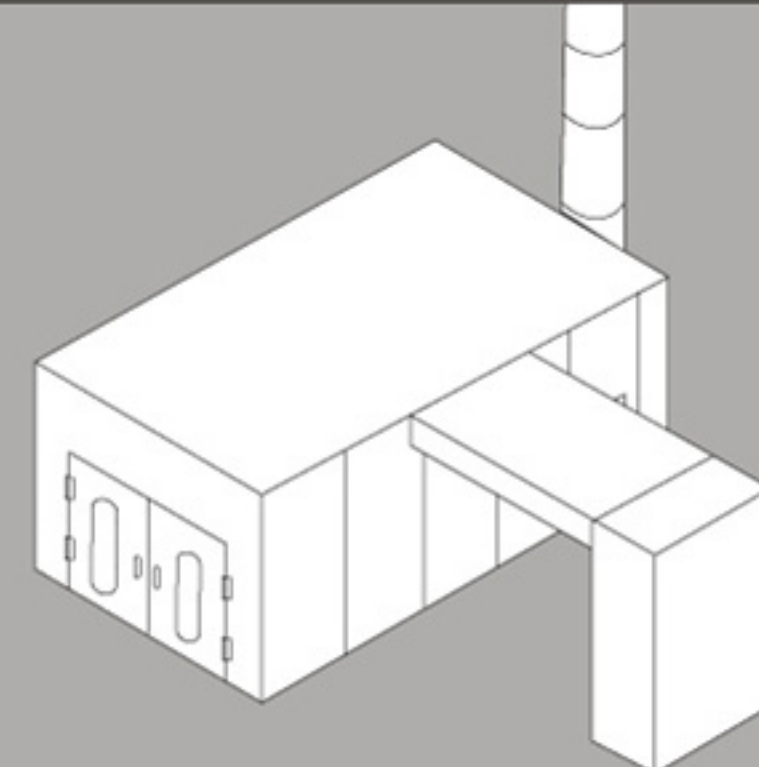

PAD [OUTSIDE] MOUNTED // HORIZONTAL DISCHARGE





SPRAYZONE.NET

SPRAY BOOTH MANUFACTURING
REFINISHING TECHNOLOGIES

CONTACT |

Toll Free
(800) 466 - 1260

Fax
562 . 790 . 8079

ONLINE |

Website
www.SprayZone.net

E-mail
Spraybooth@SprayZone.net

ADDRESS |

SPRAYZONE.NET
14059 Garfield Ave.
Paramount, CA 90723